



**ICC Evaluation Service, Inc.**  
[www.icc-es.org](http://www.icc-es.org)

**Business/Regional Office** ■ 5360 Workman Mill Road, Whittier, California 90601 ■ (562) 699-0543  
**Regional Office** ■ 900 Montclair Road, Suite A, Birmingham, Alabama 35213 ■ (205) 599-9800  
**Regional Office** ■ 4051 West Flossmoor Road, Country Club Hills, Illinois 60478 ■ (708) 799-2305

## Legacy report on the BOCA® National Building Code/1999

### DIVISION: 02—SITWORK

Section: 02350—Piles and Caissons

### REPORT HOLDER:

MACLEAN DIXIE, LLC  
3098 PELHAM PARKWAY  
PELHAM, ALABAMA 35124  
(205) 685-5413  
[www.MacLeanPower.com](http://www.MacLeanPower.com)

### EVALUATION SUBJECT:

DIXIE ANCHORING HELICAL FOUNDATION SYSTEM  
(DixieHFS™)

### EVALUATION SCOPE

Compliance with the following codes:

#### BOCA® National Building Code/1999

- Section 106.4 Alternative materials and equipment
- Section 1705.3.1 Inspection of steel fabricators
- Section 1705.3.3.2 Welding
- Section 1807.1 Design loads
- Section 1817.1 Determination of allowable loads
- Section 2203.1 General - Structural Steel Construction

### DESCRIPTION

#### ■ General

The DIXIE Anchoring Helical Foundation System (DixieHFS™) is used to form deep foundations for new structures, to provide bearing for new foundations, to underpin foundations of existing structures, and to retrofit or remediate deficient foundations of existing structures.

Dixie Anchoring fabricated steel piles (foundation anchors) consist of helical steel lead shafts with extension shafts. The foundation attachments (lifting brackets) connect the foundation anchors to the foundation of the structure. Evaluation of the foundation attachments is outside the scope of this report.

#### ■ Helical Steel Piles (Foundation Anchors)

Helical Steel Piles (Foundation Anchors) consist of an anchor lead section with one, two, three, or four circular helical-shaped steel plates welded to a central steel hub, and

extension shafts. The  $\frac{3}{8}$ -inch (9.5 mm) or  $\frac{1}{2}$ -inch-thick (12.7 mm) steel plate conforms to ASTM A36. The outer plate diameter ranges from 6 to 15 inches (152 to 381 mm) with an inner annulus of  $1\frac{1}{4}$ ,  $1\frac{1}{2}$ , or  $1\frac{3}{4}$  inches (32, 38, or 44 mm) square. The plate is formed with all radial sections normal to the central longitudinal axis, +/- 3 degrees. The helix pitch is 3 inches (76 mm). The extension shaft and central hub of the lead section are manufactured from  $1\frac{1}{4}$ -,  $1\frac{1}{2}$ -, or  $1\frac{3}{4}$ -inch (32, 38, or 44 mm) round-cornered steel bars conforming to ASTM A576, Grade 1045 or Grade 1530.

Extension shaft coupling bolts shall be  $\frac{5}{8}$ -inch (15.9 mm),  $\frac{3}{4}$ -inch (19.1 mm) or  $\frac{7}{8}$ -inch-diameter (22.2 mm) complying with ASTM A325, Type 1 with nuts conforming to ASTM A563, Grade DH. Hot dipped, galvanized zinc coating conforming to ASTM A153, Class B1 is applied to the components after fabrication, with the exception of the fasteners, which receive a Class C coating. See Figure 1 of this report for the four foundation anchor lead sections and extension shaft.

The depth of the foundation anchors into the soil is increased by connecting extension shaft sections to the anchor lead section. The extension and lead shafts are mechanically coupled to form a continuous steel pile. The lead section has provisions at the top for a connection to an extension and has an earth penetrating pilot tip at the bottom. The extensions, available with and without helical-shaped steel plates, have provisions for a coupler at one end and a bolted connection at the opposite end.

#### ■ Foundation Attachments (Lifting Brackets)

The foundation attachments (lifting brackets) are used to address foundation settlement. The brackets are outside the scope of this report. See Figure 2 of this report for an illustration of a typical lifting bracket.

### CONDITIONS OF USE

This report is limited to the applications and products as stated in this report. The ICC-ES Subcommittee on National Codes intends that the report be used by the code official to determine that the report subject complies with the code requirements specifically addressed, provided that this product is installed in accordance with the following conditions:

- DIXIE Anchoring Helical Foundation System (DixieHFS™) shall be installed in accordance with this research report and the manufacturer's published installation instructions by installers certified by Dixie Anchoring Systems™. The installation shall comply with the approved construction documents, and the following:

*ICC-ES legacy reports are not to be construed as representing aesthetics or any other attributes not specifically addressed, nor are they to be construed as an endorsement of the subject of the report or a recommendation for its use. There is no warranty by ICC Evaluation Service, Inc., express or implied, as to any finding or other matter in this report, or as to any product covered by the report.*

- The rotation rate of the foundation anchors during installation shall be between 5 to 20 rpm.
- If used, extensions shall be connected to the foundation anchor lead sections with the bolts as specified. The bolts shall be tightened to 50 ft-lbs. (68 N-m) of torque.
- The foundation anchors shall be installed to a minimum depth to the top helix of 5 feet (1524 mm).
- Bearing areas on the attachment seat angle not exceeding 100 square inches (64500 mm<sup>2</sup>) shall be used to calculate the concrete bearing stress at the seat of the foundation brackets.
- DIXIE Anchoring Helical Foundation System shall be limited to applications where the allowable axial loading of the anchor, determined as the lesser of the tensile or compressive capacity, does not exceed the allowable loads as indicated in Tables 1, 2, and 3 of this report, and the requirements of the construction documents. The allowable loads presented in the tables do not consider soil conditions.
- Special inspections of the installation of DIXIE Anchoring Helical Foundation Systems shall be provided in accordance with Section 1705.9 of the BOCA<sup>®</sup> *National Building Code/1999*. Items to be confirmed by the special inspector shall include, but not be limited to, evidence of certification of installers by manufacturer, verification of adequacy of soil for installation, the installation torque of the foundation anchor, correct attachment of the foundation anchor to the building structure via lifting brackets, or other means, as specified on the construction documents, and compliance of the installation with the approved construction documents and this report.
- Determination of capacity in soft soils, including loose cohesion-less soils, soft organic soils or soft clays, is beyond the scope of this report. Verification that the proposed foundation anchor location or locations do not include "soft soils" shall be included in the soils investigation report required in this report.
- The use of the DIXIE Anchoring Helical Foundation System described in this report is limited to undisturbed soils that have been determined, by the licensed design professional responsible for the construction documents required in this report, to provide support of the foundation anchor against lateral buckling, and to meet the requirements of Sections 1804.1 and 1804.2 of the BOCA<sup>®</sup> *National Building Code/1999*.
- Evaluation of the durability of the galvanized coating in the soil, in which the anchoring system is to be placed, is outside the scope of this report.
- Evaluation of the lifting bracket and the connection between the bracket and the foundation is outside the scope of this report and shall be included in the construction documents and subject to the specific approval of the code official.
- Dixie foundation anchors have been evaluated for vertical loading in accordance with Tables 1, 2, and 3 of this report. Other forms of loading are outside the scope of this report.
- Tieback anchoring applications are outside the scope of this report.
- This report is subject to periodic re-examination. For information on the current status of this report, contact the ICC-ES.

#### ITEMS REQUIRING VERIFICATION

The following items are related to the installation of the report subject, but are not within the scope of this evaluation. However, these items are related to the determination of code compliance:

- U Construction documents, including design calculations, indicating compliance with this report.

#### INFORMATION SUBMITTED

- Manufacturer's engineering manual, product specifications, and published installation instructions.
- *DIXIE Electrical Manufacturing Company Quality System Manual*, Revision C, dated December 01, 2000, signed by Wayne D. Mitchell - President, and Eric Hundley of the third-party inspection agency, SGS U.S. Testing Company Inc., containing criteria for independent inspections, in-house quality assurance, periodic reevaluation of production, installation, and identification of Dixie Anchoring Systems.
- Copies of the AWS certification for welders employed by DIXIE Electrical Manufacturing Company.
- Stress analysis of load bearing plate at anchor shaft contact point, dated April 10, 2001, prepared and signed and sealed by E. Dziedzic, P.E.
- Materials Technology, Lab No. 70375, dated March 7, 1997, containing axial load testing in accordance with CAN/CSA-C83-M87, for the 1<sup>1</sup>/<sub>2</sub>- and 1<sup>3</sup>/<sub>4</sub>-inch (38 and 44 mm) hub with various helix thickness and diameter combinations, signed by Paul A. Whitcomb.
- Materials Technology, Lab No. 0405-002-60289, dated February 12, 1996, containing axial load testing for shaft coupling connection, signed by Paul A. Whitcomb.
- Materials Technology, Lab No. 11368, dated June 5, 2001, containing testing to verify properties of 1<sup>1</sup>/<sub>4</sub>-inch (32 mm) ASTM A576 square bar material, signed by Paul A. Whitcomb.
- Materials Technology, Lab No. 72759, dated December 12, 1997, containing tensile load testing for shaft coupling connection, signed by Paul A. Whitcomb.
- Materials Technology, Lab No. 62779, dated November 21, 1996, containing tensile load testing for shaft coupling connection, signed by Paul A. Whitcomb.
- Materials Technology, Lab No. 71073, dated May 12, 1997, containing axial load testing for 1<sup>1</sup>/<sub>2</sub>-inch (38 mm) hub with 0.375 in. (9.5 mm) helix thickness and 10.0 in. (254 mm) diameter, signed by Paul A. Whitcomb.
- Newton Engineering & Metallurgical Services, Test No. TR92025, dated August 12, 1992, containing tensile load testing for shaft coupling connection, signed by A. Reid.
- Structural calculations, dated September, 11, 2001, revisions dated October 15, 2001, evaluating weld connection strength for the anchors, prepared by Sam Shah, P.E., signed and sealed by Ed Dziedzic, P.E.

#### APPLICATION FOR PERMIT

To aid in the determination of compliance with this research report, the following represents the minimum level of information to accompany the application for permit:

- The language "See ICC-ES Legacy Report No. 21-47" or a copy of this report.
- Construction documents consistent with this report. The individual preparing such documents shall be competent and qualified in the application of the engineering design principles involved, and shall possess registration or license in accordance with the professional registration laws of the state in which the project is constructed. The following items, at a minimum, shall be provided on the construction documents:

- Brackets and connections used to secure the Dixie foundation anchors to the building or structure.
- Required spacing of the foundation anchors.
- Placement angles of the foundation anchors.
- A soil investigation report for the proposed construction site provided by a registered design professional, qualified to perform such work. Information provided in the soils investigation report shall include, but not be limited to, the following:
  - Soil type at each strata along the length of the proposed foundation anchors installation.
  - Allowable soil bearing pressure.
  - Indication of the method used by the registered design professional to determine that the soil is adequate for the proposed installation.
  - Properties affecting the design of the system, including the lateral load carrying capacity of the soil at each strata.
  - Location of the ground water table.
  - Maximum anticipated frost depth.
  - The presence or absence of corrosives in the soil and the appropriateness of the use of galvanized steel in the soil.
  - The presence of stone, rocks or other debris in the soil strata and their effects on the suitability of the soil for use with Dixie foundation anchors.
  - Recommendations to the registered design professional to prevent settlement due to ground water or overloading of the soil, wall damage due to frost heave or corrosion of the pier materials and the characteristics of the appropriate types of loading for the soil.
- Suitability of the systems in a seismic area for areas required to submit seismic calculations.
- Structural calculations which shall include, but not be limited to, the following:
  - Ability of the soil to provide lateral stability to the Dixie foundation anchors.
  - Effects of seismic loads on the DIXIE Anchoring Helical Foundation System, where required.
  - Settlement analysis of the foundation anchors under design load shall be provided. The analysis shall demonstrate that the Dixie Helical Steel Piles (Foundation Anchors) transfer the design loads to the soil without causing any stresses within the structure to exceed their respective allowable stress values.
  - Ability of all connections between the building structure and the DIXIE Anchoring Helical Foundation System to transfer the imposed loads.
  - Ability of the concrete slab and/or foundation/footings system to transfer the imposed loads to the DIXIE Anchoring Helical Foundation System.

#### **PRODUCT IDENTIFICATION**

DIXIE Anchoring Helical Foundation System (DixieHFS™) components or packaging manufactured in accordance with this report shall bear the following identification:

- “See ICC-ES Legacy Report No. 21-47”
- A label that identifies the product and catalog number, the company name, and the third-party inspection agency name or logo (SGS U.S. Testing Company, Inc.).

**TABLE 1**  
**FOUNDATION ANCHOR MECHANICAL STRENGTH RATINGS SINGLE HELIX ANCHORS**

CATALOG NUMBER	SHAFT LENGTH (in.)	SHAFT WIDTH (in.)	HELIX DIAMETER (in.)	HELIX THICKNESS (in.)	ALLOWABLE AXIAL LOAD (lbs) <sup>1</sup>
N-6202-0001	9 1/2	1.25	6	0.375	17500
N-6202-0002	9 1/2	1.25	8	0.375	17500
N-6202-0003	9 1/2	1.25	10	0.375	17500
N-6202-0004	9 1/2	1.25	12	0.375	17500
N-6202-0005	9 1/2	1.25	14	0.375	17500
N-6202-0006	84	1.25	8	0.375	17500
N-6202-0007	84	1.25	10	0.375	17500
N-6202-0008	84	1.25	12	0.375	17500
N-6202-0009	84	1.25	14	0.375	17500
N-6202-0010	84	1.25	15	0.375	17500
N-6203-0018	9 1/2	1.50	6	0.375	26900
N-6203-0019	9 1/2	1.50	8	0.375	26900
N-6203-0020	9 1/2	1.50	10	0.375	26900
N-6203-0021	9 1/2	1.50	12	0.375	26900
N-6203-0022	9 1/2	1.50	14	0.375	26900
N-6203-0001	60	1.50	8	0.375	26900
N-6203-0002	60	1.50	10	0.375	26900
N-6203-0003	60	1.50	12	0.375	26900
N-6203-0004	60	1.50	14	0.375	26900
N-6203-0009	84	1.50	8	0.375	26900
N-6203-0010	84	1.50	10	0.375	26900
N-6203-0012	84	1.50	14	0.375	26900
N-6203-0032	60	1.50	8	0.500	50000
N-6203-0033	60	1.50	10	0.500	50000
N-6203-0013	60	1.50	12	0.500	50000
N-6203-0014	60	1.50	14	0.500	43000
N-6203-0007	84	1.50	8	0.500	50000
N-6203-0008	84	1.50	10	0.500	50000
N-6203-0011	84	1.50	12	0.500	50000
N-6203-0034	84	1.50	14	0.500	43000

**For SI:** 1 in. = 25.4 mm, 1 lb = 4.4 N

1. Loads apply to anchor or extension capacity only. Other factors, such as soil interaction, bracket, and foundation/footing capacity connections are outside the scope of this report and shall be considered as required by this report. The allowable axial load reflects the lesser of the tension or compression capacity.

**TABLE 2**  
**FOUNDATION ANCHOR MECHANICAL STRENGTH RATINGS**  
**DOUBLE HELIX, TRIPLE HELIX, QUADRUPLE HELIX ANCHORS**

CATALOG NUMBER	SHAFT LENGTH (in.)	SHAFT WIDTH (in.)	HELIX DIAMETER (in.)				HELIX THICKNESS (in.)	ALLOWABLE AXIAL LOAD (lbs) <sup>2</sup>
			1st	2nd	3rd	4th		
<b>DOUBLE HELIX ANCHORS</b>								
			1st	2nd	3rd	4th		
N-6202-0011	84	1.25	8	10	NA	NA	0.375	31420
N-6203-0005	60	1.50	6	6	NA	NA	0.375	50000
N-6203-0006	60	1.50	6	8	NA	NA	0.375	50000
N-6203-0025	60	1.50	8	10	NA	NA	0.375	50000
N-6203-0026	60	1.50	10	12	NA	NA	0.375	50000
N-6203-0027	84	1.50	6	8	NA	NA	0.375	50000
N-6203-0028	84	1.50	8	10	NA	NA	0.375	50000
N-6203-0029	84	1.50	10	12	NA	NA	0.375	50000
N-6203-0017	120	1.50	8	10	NA	NA	0.375	50000
N-6203-0023	60	1.50	8	10	NA	NA	0.500	50000
N-6203-0024	60	1.50	10	12	NA	NA	0.500	50000
N-6206-0002	60	1.75	8	10	NA	NA	0.375	50000
N-6206-0003	60	1.75	10	12	NA	NA	0.375	50000
<b>TRIPLE HELIX ANCHORS</b>								
			1st	2nd	3rd	4th		
N-6202-0012	84	1.25	8	10	12	NA	0.375	31420
N-6203-0030	84	1.50	8	10	12	NA	0.375	50000
N-6203-0031	84	1.50	10	12	14	NA	0.375	50000
N-6206-0004	84	1.75	8	10	12	NA	0.375	50000
N-6206-0005	84	1.75	10	12	14	NA	0.375	50000
<b>QUADRUPLE HELIX ANCHORS</b>								
			1st	2nd	3rd	4th		
N-6203-0015	120	1.50	8	10	12	14	0.500	50000
N-6203-0016	120	1.50	10	12	14	14	0.500	50000
N-6206-0006	120	1.75	8	10	12	14	0.375	50000
N-6206-0007	120	1.75	10	12	14	14	0.375	50000

**For SI:** 1 in. = 25.4 mm, 1 lb = 4.4 N

1. NA = Not Applicable

2. Loads apply to anchor or extension capacity only. Other factors, such as soil interaction, bracket, and foundation/footing capacity connections are outside the scope of this report and shall be considered as required by this report. The allowable axial load reflects the lesser of the tension or compression capacity.

**TABLE 3  
FOUNDATION ANCHOR MECHANICAL STRENGTH RATINGS  
STANDARD, SINGLE HELIX, AND MULTI-HELIX EXTENSIONS**

CATALOG NUMBER	SHAFT LENGTH (in.)	SHAFT WIDTH (In.)	HELIX DIAMETER (in.)		HELIX THICKNESS (in.)	ALLOWABLE AXIAL LOAD (lbs) <sup>2</sup>
			1st	2nd		
N-6401-0016	42	1.25	NA	NA	NA	31420
N-6401-0017	60	1.25	NA	NA	NA	31420
N-6401-0018	84	1.25	NA	NA	NA	31420
N-6401-0019	120	1.25	NA	NA	NA	31420
N-6401-0004	42	1.50	NA	NA	NA	50000
N-6401-0005	60	1.50	NA	NA	NA	50000
N-6401-0006	84	1.50	NA	NA	NA	50000
N-6401-0007	120	1.50	NA	NA	NA	50000
N-6401-0024	60	1.50	10	NA	0.375	26900
N-6401-0025	60	1.50	12	NA	0.375	26900
N-6401-0026	84	1.50	14	NA	0.375	26900
N-6401-0008	42	1.75	NA	NA	NA	50000
N-6401-0009	60	1.75	NA	NA	NA	50000
N-6401-0010	84	1.75	NA	NA	NA	50000
N-6401-0011	120	1.75	NA	NA	NA	50000
N-6401-0020	60	1.75	12	NA	0.375	30650
N-6401-0021	60	1.75	14	NA	0.375	30650
N-6401-0027	84	1.75	14	14	0.375	50000

For SI: 1 in. = 25.4 mm, 1 lb = 4.4 N

1. NA = Not Applicable
2. Loads apply to anchor or extension capacity only. Other factors, such as soil interaction, bracket, and foundation/footing capacity connections are outside the scope of this report and shall be considered as required by this report. The allowable axial load reflects the lesser of the tension or compression capacity.

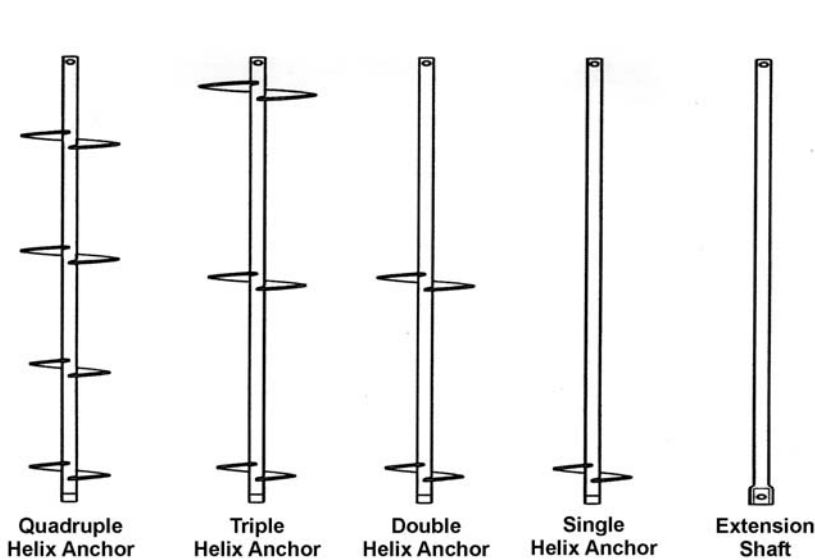

**FIGURE 1\***

**FOUNDATION ANCHOR LEAD SECTIONS CONFIGURATIONS AND EXTENSION SHAFT**

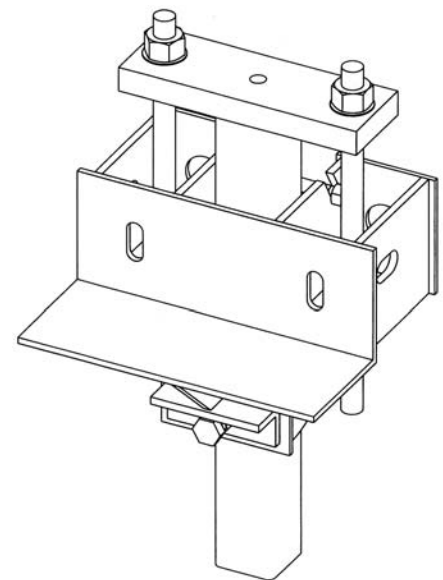

**FIGURE 2\***

**TYPICAL FOUNDATION ATTACHMENT (LIFTING BRACKET)  
(EVALUATION OF THE BRACKET IS OUTSIDE THE SCOPE OF THIS REPORT AND SUBJECT TO THE SPECIFIC APPROVAL OF THE CODE OFFICIAL.)**

\*THESE DRAWINGS ARE FOR ILLUSTRATION PURPOSES ONLY. THEY ARE NOT INTENDED FOR USE AS CONSTRUCTION DOCUMENTS FOR THE PURPOSE OF DESIGN, FABRICATION OR ERECTION.