



ICC Evaluation Service, Inc.
www.icc-es.org

Business/Regional Office ■ 5360 Workman Mill Road, Whittier, California 90601 ■ (562) 699-0543
Regional Office ■ 900 Montclair Road, Suite A, Birmingham, Alabama 35213 ■ (205) 599-9800
Regional Office ■ 4051 West Flossmoor Road, Country Club Hills, Illinois 60478 ■ (708) 799-2305

Legacy report on the BOCA® National Building Code/1999

DIVISION: 2—SITWORK
Section: 02465—Bored Piles

REPORT HOLDER:

**A.B. CHANCE COMPANY / HUBBELL POWER
SYSTEMS, INC.**
210 NORTH ALLEN STREET
CENTRALIA, MISSOURI 65240-1395
www.abchance.com

EVALUATION SUBJECT:

HELICAL PIER FOUNDATION SYSTEM

1.0 EVALUATION SCOPE

Compliance with the following code:

- BOCA® National Building Code/1999 (BNBC)

Properties evaluated:

- Structural

2.0 USES

The Helical Pier Foundation System is intended for use as foundation underpinning in undisturbed soils.

3.0 DESCRIPTION

3.1 General:

The system consists of a lead section with helical plates, shaft extensions, and a foundation support bracket. The lead section is placed in the soil with mechanical rotation. Depending on the application, the depth of the lead section of the helical piers in the soil is extended to the required depth by adding one or more shaft extensions coupled to the lead section. The foundation repair bracket is used to support a building footing and is attached to a helical pier.

3.2 System Components:

3.2.1 Lead Section: The lead section of the helical foundation system, as shown in Figure 1, consists of circular steel plates welded to a central steel shaft.

The shaft of the lead section is round cornered square (RCS) solid steel bars. The RCS bar is 1¹/₂-inch-square (38 mm) and is formed of ASTM A 29 steel. Material

specifications for the steel shaft are as presented in Table 1 of this report.

The minimum diameter of the helical steel plate is 6 inches, and the maximum is 14 inches (356 mm). The center of the plate is punched out to accept the pier shaft. Each helical plate is formed so that all radial sections of the plate are normal to the central longitudinal axis ± 3 degrees. The pitch of the helix is 3 inches (76 mm). The helical plates are ³/₈-inch-thick (9.5 mm). The material specifications for the helical plates are noted in Tables 1 and 2 of this report.

The size of the helical plates remains the same, or increases as they are placed up the shaft of the lead section, as shown in Figure 1 and Table 1. The size of the plates used depends on the required bearing capacity of the pier and the soils into which the pier is to be installed. The spacing between any two helical plates on the central shaft is nominally three times the diameter of the lower helix.

Each lead section of helical steel pier has a coupler means on the top end and an earth penetrating pilot on the bottom. The connection means consists of a hole drilled perpendicular to the central axis near the end of the shaft, to accommodate a bolted connection to extensions or support brackets.

Once the plates are welded to the central shaft and the coupler and pilot ends formed, the entire assembly is hot dipped galvanized in accordance with ASTM A 153. The maximum design strengths of the helical pier foundation systems, based on the lead section used and Load Resistant Factored Design (LRFD), are given in Table 1.

3.2.2 Extensions: Extensions consist of the same size steel shaft described above for the lead section, with or without 14-inch (356 mm) helical plates. The dimensions and material specifications for the steel shaft and the helical plates are as described above, and each extension assembly is also hot dipped galvanized in accordance with ASTM A 153. The extensions are shown in Figures 2 and 3. Technical data for the extension shaft and the coupling connection is given in Table 2.

Each extension has a coupler means on one end and a connection means on the other. The coupler at the end of the central shaft is an integrally forged socket that slips over the connection means at the end of the preceding lead section or extension. Each socket has a transverse hole in the socket to facilitate connection of lead sections and extensions with a bolt and nut. The connection and coupling means of the coupler connection are shown on the extension in Figures 2 and 3.

ICC-ES legacy reports are not to be construed as representing aesthetics or any other attributes not specifically addressed, nor are they to be construed as an endorsement of the subject of the report or a recommendation for its use. There is no warranty by ICC Evaluation Service, Inc., express or implied, as to any finding or other matter in this report, or as to any product covered by the report.

3.2.3 Foundation Bracket: The foundation bracket consists of upper and lower steel bracket bodies which are interconnected with two lifting bolts, as shown in Figure 4. Table 3 gives design data for the foundation bracket.

The brackets are formed of $1/4$ - and $3/8$ -inch-thick (6 mm and 9.5 mm) ASTM A 36 steel. The stem of the T-shaped upper bracket is an 18-inch-long hot rolled electrical resistance welded round steel tubing which complies with ASTM A 512 or ASTM A 513 Grade 1020, with a minimum yield and tensile strength of 50 and 62 ksi (344738 and 427475 kPa), respectively. Both the upper and lower brackets have an ASTM A 153, Grade B-1 hot dipped galvanized coating.

The lifting bolts are $7/8$ -inch-diameter (22 mm), comply with SAE J429, Grade 2, and have a minimum yield strength of 36 ksi (248211 kPa) and a minimum tensile strength of 60 ksi (413685 kPa). Cross bolts are also required to support the eccentric load of the foundation on the helical pier extension. These cross bolts are $5/8$ -inch-diameter (16 mm), comply with SAE J429, Grade 5, and have a minimum yield and tensile strength of 92 and 120 ksi (634318 and 827370 kPa) respectively.

4.0 INSTALLATION

4.1 General:

Installation of Helical Pier Foundation System shall comply with this report and the published manufacturer's installation instructions. The manufacturer's published installation instructions shall be available at the jobsite at all times during installation.

4.2 Helical Pier:

The helical pier shall be installed in undisturbed soil with rotary motors that are capable of rotating clockwise or counterclockwise. The torque applied during the installation of the final length of the helical pier shall be recorded. Ultimate bearing capacity of the soil for the installed pier is determined by multiplying the final installation torque of the pier by the load factor for the lead section, as given in Table 1.

The piers are rated by the maximum torque permitted to be used to complete their installation. Torque ratings for the lead sections and extensions are given in Tables 1 and 2. The minimum required torque rating for each extension shall be equal to or greater than the torque rating of the lead section it is used with.

4.3 Foundation Bracket:

The T-shaped upper bracket body is slid over the end of the topmost extension of the installed helical steel pier. The lower bracket is attached to the foundation with anchors bolts, as specified in the approved construction documents required in Sections 5.9 and 5.10 of this report. The lower bracket body is attached to the upper bracket body with the lifting bolts. A jacking tool with cross plate is connected to the top of the lifting bolts, and a jack is placed between the cross plate and the top of the T-bracket, as shown in Figure 5. In this manner the jack is used to lift the lower bracket body as it pushes down on the T-shaped section of the upper bracket body, and indirectly loads the extension of the helical pier. Once the lower bracket has been lifted to the desired height, the nuts on the lifting bolts are tightened, and the jack removed.

5.0 CONDITIONS OF USE

This report is limited to the applications and products as stated in this report. The ICC-ES Subcommittee on National Codes intends that the report be used by the code official to determine that the report subject complies with the code requirements specifically addressed, provided that this product is installed in accordance with the following conditions:

- 5.1 The Helical Pier Foundation System shall be limited to applications where the required bearing and uplift capacity of the anchor does not exceed that determined through application of Table 1 of this report, and the recommendations of the construction documents required in Sections 5.9 and 5.10 of this report.
- 5.2 The Helical Pier Foundation System shall be installed in accordance with this research report and the manufacturer's recommendations, by installers certified by the manufacturer. The installation shall comply to the approved construction documents, and the following:
 - 5.2.1 The anchor shall be positioned and angled as specified in the approved construction documents.
 - 5.2.2 The rotation rate of the helical piers during installation shall be between 5 to 20 revolutions a minute.
 - 5.2.3 If used, extensions shall be connected to the helical pier with the bolts specified in Table 2. The bolts shall be tightened to 40 ft-lbs (401 N·m) of torque.
 - 5.2.4 The piers shall be installed to the minimum depth shown on the approved construction documents, with a minimum depth to the top helix of 5 feet.
 - 5.2.5 Each extension used with the lead sections shall have a minimum torque rating, as shown in Table 2, equal to or greater than the torque rating of the lead section, as given in Table 1.
- 5.3 Special Inspections of the installation of helical piers shall be provided in accordance with Section 1705.9 of the BOCA[®] *National Building Code/1999*. Items to be confirmed by the Special Inspector shall include, but not be limited to, evidence of certification of installers by manufacturer, verification of adequacy of soil for installation, the installation torque of the pier, correct jacking of the foundation onto the pier and compliance of the installation with the approved construction documents and this report.
- 5.4 The factored design load on the helical pier shall not be greater than the lowest value determined from the following:
 - 5.4.1 The design soil bearing capacity of the anchor, determined by multiplying the installation torque, in ft-lbs, used to install the final length of the pier by the load factor given in Table 1 of this report, and a strength reduction factor, $N = 0.70$.
 - 5.4.2 The maximum design strength, P_D , given for the lead section in Table 1 of this report.
- 5.5 The capacity of the anchor in all but soft soils shall be determined in the manner described in Section 5.4. Determination of capacity in soft soils, including loose cohesionless soils, soft organic soils or soft clays, is beyond the scope of this report. Verification that the proposed pier location or locations do not include "soft soils" shall be included in the soils investigation report required in Section 5.10 of this report.

- 5.6** Factored design loads on the foundation bracket, based on LRFD, shall not exceed 24.1 kips (10, 941 kg). Other brackets, or other means of securing the helical pier to the building or structure supported are beyond the scope of this report. All connections used in conjunction with the helical pier shall be designed by a registered design professional, as required by Section 5.9 of this report.
- 5.7** The use of the helical piers described in this report is limited to undisturbed soils that have been determined by the registered design professional responsible for the construction documents described in Section 5.10 of this report to be adequate to provide support of the helical pier against lateral buckling, and to meet the requirements of Section 1804.2 of the BOCA® *National Building Code/1999* as satisfactory foundation material.
- 5.8** Evaluation of the durability of the galvanized coating in the soil it is to be placed in is outside the scope of this report.
- 5.9** All permit applications for helical piers shall be accompanied by structural calculations which are performed by a registered architect or engineer who is qualified to perform them in accordance with the registration laws of the state in which construction is to take place. Items addressed in the structural calculations shall include, but not be limited to, the following:
- 5.9.1** All brackets and connections used to secure the Helical Pier to the building or structure.
- 5.9.2** Column buckling of the piers due to compression loads, based on the lateral load carrying capacity of the soil, as given in the soil investigation report required in Section 5.10 of this report.
- 5.9.3** The effects of seismic loads on the helical pier, as required in Sections 1610.0 and 1802.1.1 of the BOCA® *National Building Code/1999*.
- 5.9.4** The required spacing of the anchors.
- 5.9.5** A settlement analysis of the helical piers under design load shall be provided, as required by Section 1816.19 of the BOCA® *National Building Code/1999*. The analysis shall demonstrate that the predicted settlement of the piers shall not cause harmful distortion of, or instability in, the structure supported, nor cause any stresses within the structure to exceed allowable values.
- 5.9.6** The angle at which the pier is to be placed.
- 5.10** A soils investigation report for the proposed construction site shall be provided by a registered design professional qualified to perform such work, with each permit application. Information provided in the soils investigation reports shall include, but not be limited to, the following:
- 5.10.1** The type of soil at each strata along the length of the proposed pier installation.
- 5.10.2** The allowable soil bearing pressure.
- 5.10.3** Indication of the method used by the registered design professional to determine that the soil is adequate for the proposed installation.
- 5.10.4** Properties affecting the design of the system, including the lateral load carrying capacity of the soil at each strata.
- 5.10.5** The location of the ground water table.
- 5.10.6** The maximum anticipated depth of frost.
- 5.10.7** The presence or absence of corrosives in the soil and the appropriateness of the use of galvanized steel in the soil.
- 5.10.8** The presence of stone, rocks or other debris in each soil strata, and their effect on the suitability of the soil for use with the Helical Pier system.
- 5.10.9** Recommendations to the registered design professional to preclude settlement due to ground water or overloading of the soil, wall damage due to frost heave or corrosion of the pier materials and the characteristics of the appropriate types of loading for the soil.
- 5.10.10** Suitability of the system in a seismic area for areas required to have seismic calculations in Section 5.9.2 of this report.
- 5.11** This report is subject to periodic re-examination. For information on the current status of this report, contact the ICC-ES.

6.0 EVIDENCE SUBMITTED

- 6.1** LBA, Inc., Report on a Load Test of an A.B. Chance Helical Pier, dated November 3, 1992, stamped by Carl Bobish, P.E.
- 6.2** CTL/Thompson, Inc., Axial Compressive Load Test, dated February 5, 1993, stamped by Robert U. Branson, P.E.
- 6.3** Chen Northern, Inc., Observation of Helical Anchor Pile Load Test at West High School, 9th Avenue and Galapago Street, Denver, CO., dated May 28, 1992, stamped by Michael Riggins, P.E.
- 6.4** BBC & M Engineering, Inc, Load Testing Results, Thompson and Avery Road Sites, dated August 31, 1992, signed by Robert Thompson, P.E.
- 6.5** Report of Full-Scale Load Tests on Helical Anchors, dated June 23, 1995, by Engineering Surveys and Services.
- 6.6** Pressure Distribution Beneath a Bearing Plate Resulting from a Compressive Load Being Applied to a Helical Pier Foundation in Soil, signed and dated October 11, 1995, by Gary Seider, P.E.
- 6.7** Compression Load Tests on A.B. Chance - Helical Pier Foundation System Components, Radco Test Report No. RAD-1663, dated January, 1996, by Radco, signed by Ray Tucker, P.E.
- 6.8** Report on Full-Scale Tensile Load Tests on Helical Anchors, dated July 11, 1996, by Engineering Surveys and Services, signed by Bruce Dawson, P.E.
- 6.9** S.P. Clemence, P.E., Professor and Chairman, Civil Engineering Department, Syracuse University, *Uplift Capacity of Helical Anchors in Soil*, presented at the International Conference on Soil Mechanics and Foundation Engineering, August, 1989.

- 6.10** Letter of September 27, 1995, signed by Dr. S.P. Clemence, P.E., discussing the uplift capacity of helical piers in various types of soils based on the finding cited in *Uplift Capacity of Helical Anchors in Soil*, and comparing the test method used for that report to ASTM D3689-90 and ASTM D1143.
- 6.11** S.P. Clemence, P.E., Professor, Syracuse University, L.K. Crouch, Assistant Professor, Department of Civil Engineering, Tennessee Technological University, and R.W. Stephenson, Professor, Department of Civil Engineering, University of Missouri-Rolla, *Prediction of Uplift Capacity for Helical Anchors in Sand*.
- 6.12** Coupling Bolt Calculations, prepared and signed by Gary Seider, P.E., dated December 20, 1994 and March 1, 1995. Mr. Seider prepared calculations in accordance with AISC LRFD.
- 6.13** Stress Analysis - Foundation Repair Brackets, prepared and signed by Gary Seider, P.E. These calculations, done in accordance with AISC LRFD.
- 6.14** Compression Load Tests on A.B. Chance - Helical Pier Foundation System Components, Radco Test Report No. RAD-1663, dated January, 1996 by Radco, signed by Ray Tucker, P.E.
- 6.15** Study of Loading Tests Results of the Chance Underpinning System Tested in Centralia, Missouri, by Lymon Reese and Associates, dated December, 1993.
- 6.16** Quality Control Manual and Inspection Procedures for A.B. Chance Company, by RADCO, dated August 1994.
- 6.17** Copies of the AWS certification for weld inspectors employed by A.B. Chance.

7.0 PRODUCT IDENTIFICATION

The Helical Pier Foundation System described in this report shall be identified by a stamp bearing the manufacturer's name (A.B. Chance Company / Hubbell Power Systems, Inc.) and/or trademark, the product type, the name of the third-party inspection agency and the evaluation number (ICC-ES Legacy Report No. 94-27).

CHANCE HELICAL PIER FOUNDATION SYSTEM DETAILS

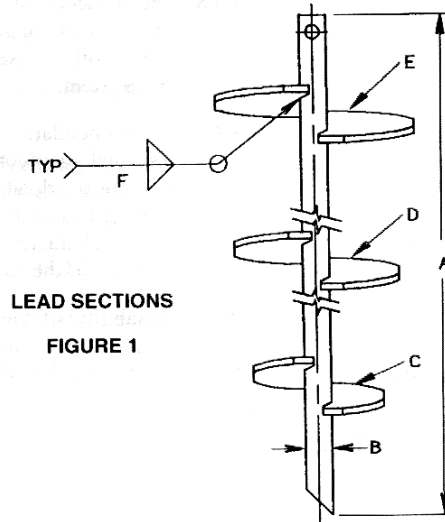

TABLE 1 — DESCRIPTION AND ULTIMATE BEARING CAPACITY OF LEAD SECTIONS

CAT. NO.	LEAD SECTION							LOAD FACTOR ¹		MAXIMUM DESIGN STRENGTH P_o^5 (kips)	HELICAL PLATE MATERIAL SPECIFICATION ²	SHAFT TYPE & SPEC.
	A	B	C	D	E	F	MAX. INSTALLATION TORQUE RATING FT.-LB.	COMPRESSION ⁴	UPLIFT ⁴			
C150-0001	7'	1-1/2"	8"	NP	NP	5/16"	(SS-5) 5,500	10	10	20	ASTM A 570 ASTM A 572 ASTM A 607 GRADE 50 $F_y = 50$ KSI MIN. $F_T = 65$ KSI MIN.	RCS SOLID STEEL BAR ASTM A 29 $F_y = 70$ ksi MIN. $F_T = 100$ ksi MIN.
C150-0002	5'	1-1/2"	8"	NP	NP	5/16"	(SS-5) 5,500	10	10	20		
C150-0003	7'	1-1/2"	10"	NP	NP	5/16"	(SS-5) 5,500	10	10	20		
C150-0004	7'	1-1/2"	12"	NP	NP	5/16"	(SS-5) 5,500	10	10	20		
C150-0005	7'	1-1/2"	14"	NP	NP	5/16"	(SS-5) 5,500	6 ³	6 ³	16		
C150-0030	7'	1-1/2"	6"	8"	NP	1/4"	(SS-5) 5,500	10	10	27.5		
C150-0006	7'	1-1/2"	8"	10"	NP	1/4"	(SS-5) 5,500	10	10	27.5		
C150-0031	10'	1-1/2"	8"	10"	NP	1/4"	(SS-5) 5,500	10	10	27.5		
C150-0007	7'	1-1/2"	8"	10"	12"	1/4"	(SS-5) 5,500	10	10	27.5		
C150-0168	2-1/2'	1-1/2"	8"	10"	NP	1/4"	(SS-7) 7,000	10	10	35.0		
C150-0169	5'	1-1/2"	8"	10"	12"	1/4"	(SS-7) 7,000	10	10	35.0		
C150-0170	10'	1-1/2"	14"	14"	14"	1/4"	(SS-7) 7,000	6 ³	6 ³	35.0	HSLA ASTM A 29 $F_y = 95$ ksi MIN. $F_T = 120$ ksi MIN.	

S.I. 1 in. = 25.4 mm; 1 ft-lb = 1.36 N•m; 1 kip = 4.45 kN; 1 ksi = 6894.8 kPa; 1 ft = 0.305 m

¹ The ultimate bearing capacity of the soil supporting the anchor is determined by multiplying the maximum torque used to fully install the lead section and extensions by the load factor given in Table 1. The load factor is a function of the lead section only.

² Grades and physical properties shown are minimum.

³ Load factor of 10 applicable in uniform homogenous deposits of clay or silty-clay soils, load factor of 6 applicable in sand or soil combinations which include sand.

⁴ Use of these load factors to determine capacity of the anchor shall be limited to those soils which are not considered soft or very soft soils, as determined by the registered design professional responsible for the preparation of the construction documents.

⁵ Based on LRFD, with $P_o = N P_u$.

NP = Not Provided

CHANCE HELICAL PIER® FOUNDATION SYSTEM DETAILS

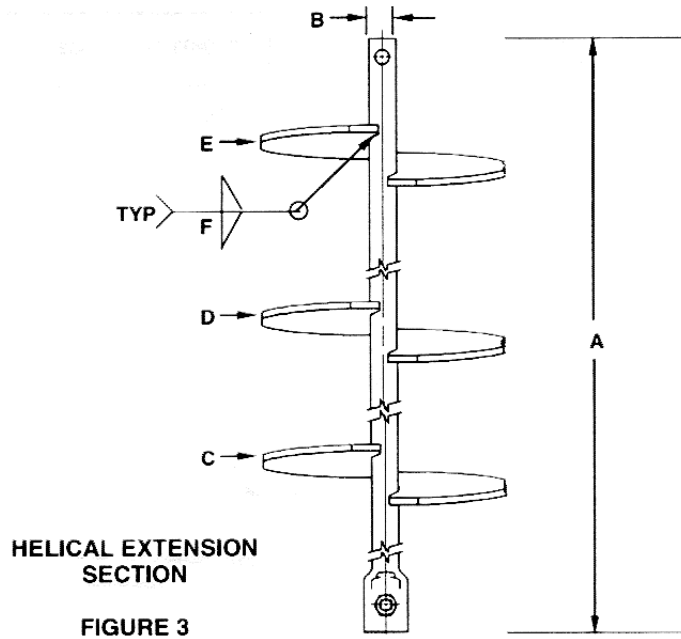
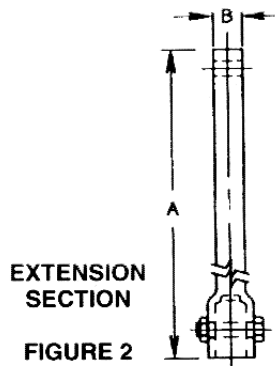
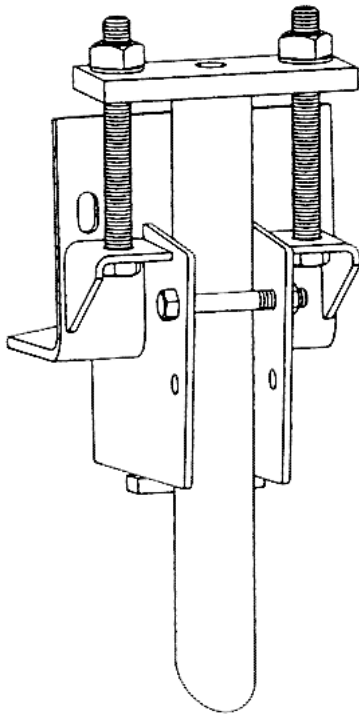

TABLE 2 — DESCRIPTION OF EXTENSIONS

CAT. NO.	EXTENSION						MAX. INSTALLATION TORQUE RATING		BOLTS			HELICAL PLATE MATERIAL SPECIFICATION	SHAFT MATERIAL SPECIFICATION
	A	B	C	D	E	F	FT.-LB.	FT.-LB.	QTY	SIZE	TYPE		
C150-0047	3-1/2'	1-1/2"					(SS-5)	5,500	1	3/4	ASTM A 320 GRADE L7	ASTM A 29 F _Y = 70 ksi MIN. F _T = 100 ksi MIN.	
C150-0008	5'	1-1/2"					(SS-5)	5,500	1	3/4			
C150-0009	7'	1-1/2"					(SS-5)	5,500	1	3/4			
C150-0048	10'	1-1/2"					(SS-5)	5,500	1	3/4			
C150-0144	3-1/2'	1-1/2"					(SS-7)	7,000	1	3/4			
C150-0145	5'	1-1/2"					(SS-7)	7,000	1	3/4			
C150-0146	7'	1-1/2"					(SS-7)	7,000	1	3/4			
C150-0175	10'	1-1/2"					(SS-7)	7,000	1	3/4			
C150-0176	4'	1-1/2"	14"			1/4"	(SS-7)	7,000	1	3/4	ASTM A 715, A 656 GRADE 80 F _Y = 80KSI min. F _T = 90KSI	HSLA ASTM A 29 F _Y = 95 MIN. F _T = 120 MIN.	
C150-0177	6-1/2'	1-1/2"	14"	14"		1/4"	(SS-7)	7,000	1	3/4			
C150-0178	10'	1-1/2"	14"	14"	14"	1/4"	(SS-7)	7,000	1	3/4			

S.I. 1 in. = 25.4 mm; 1 ft = 0.304 m; 1 ft-lb = 1.36 N•m; 1 ksi = 6894.8 kPa



**FIGURE 4
FOUNDATION BRACKET**

TABLE 3—ACCESSORY COMPONENTS

Component	Design Strength P_D^1 (kips)	Bolts Used
C150-0121 Foundation Bracket	20.0	(2) 7/8" lifting bolts (1) 5/8" cross bolt

1. Based on LRFD with $P_D = \frac{1}{2} P_U$

S.I. 1 kip = 4.45 kN; 1 in. = 25.4 mm

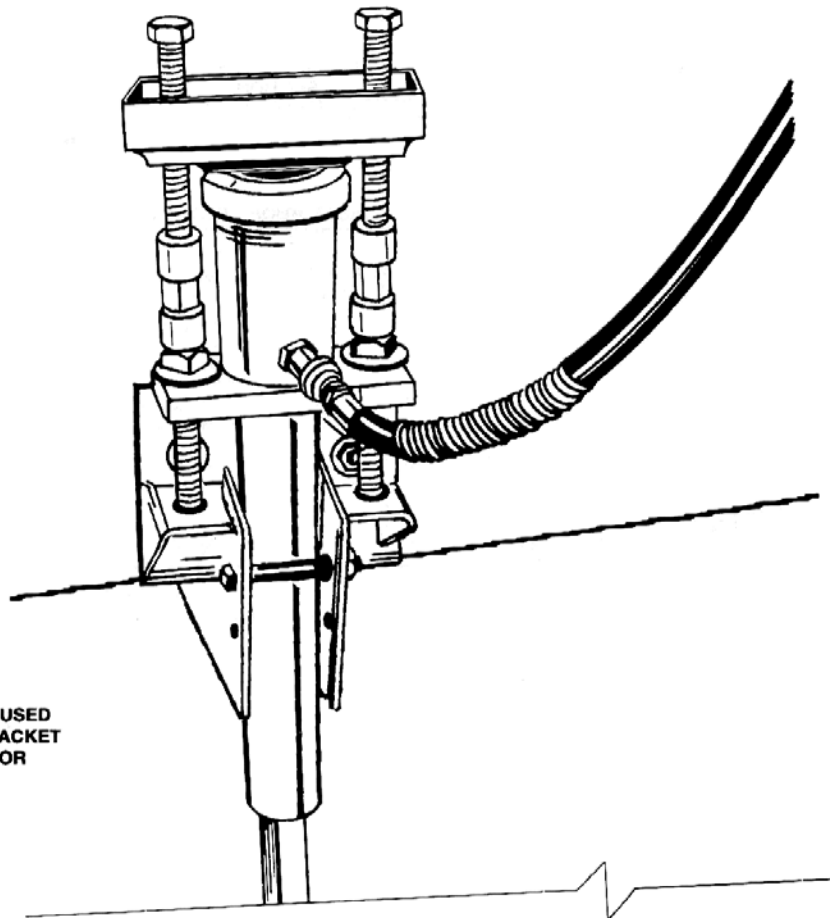

**JACKING TOOL AND JACK USED
TO PLACE FOUNDATION BRACKET
ON HELICAL PIER ANCHOR**

FIGURE 5